



DVLZ MOUNTING RING

AIR MANAGEMENT SYSTEMS

PRODUCT PROPERTIES

The tight mounting ring **DVLZ** is designed for use with circular supply and exhaust valves in order to give a complete solution for various mounting options with circular spiral and flexible ducts.

CONSTRUCTION

The mounting ring is made of steel sheet. Model **DVLZ** is NOT supplied with rubber gasket.

INSTALLATION

DVLZ is designed for fast and easy mounting both with spring connected Valves and flexible ducting.

Mounting rings **DVLZ** is easy to install with rivets or screws into the duct.

The ring can be fastened to the surrounding material with screws which go through the openings in the ring flange.

Please use screws to fit the hole.

Dimensions and weights

SIZE	A	D	Hole size
DVLZ080	107	80	Ø 90
DVLZ100	127	100	Ø 110
DVLZ125	152	125	Ø 135
DVLZ150	177	150	Ø 160
DVLZ160	187	160	Ø 170
DVLZ200	227	200	Ø 210

Height 50mm

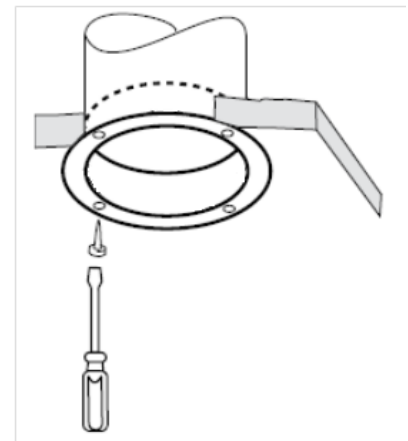
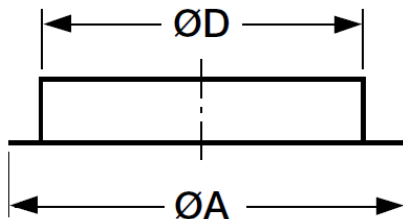

LIABILITY:

The information contained in this brochure was current on the publication date. DEC INTERNATIONAL reserves the right to make changes in details at any time without prior notice. In order to avoid misunderstandings, any interested party is advised to contact DEC INTERNATIONAL checking for any changes in materials and/or information after this brochure was published.

PLEASE NOTICE:

The consultant is responsible for the actual installation and mounting of the product. The mentioned values with respect to temperatures are not appropriate to be used to determine the physical properties. These properties are also dependent on humidity and the temperature of the air inside and outside of the H.V.A.C. system.

TRADEMARKS:

DEC International and the DEC logo are trademarks, or registered trademarks of Dutch Environment Corporation BV in the Netherlands and/or other countries.

