



DVI EXHAUST/SUPPLY AIR VALVE

AIR MANAGEMENT SYSTEMS

PRODUCT PROPERTIES

Stainless steel air valve with adjustable core

DVI is a supply valve suitable for houses, offices etc.

- Good adjusting features
- Low noise level
- Quick and easy to install
- Airflow easy to measure
- Suitable for rooms with a high air humidity (e.g. Kitchen, bathroom)
- Manufactured from Brushed Stainless Steel 304
- Air flow control
- High valve body improving air flow/less noise with spring fastening
- Simple removal for cleaning
- Including Fixingcollar with spring fastening

CONSTRUCTION

The **DVI** is manufactured from brushed stainless steel. The valve body has a gasket, made of cellular plastic and the control disc, with screw spindle, enables easy regulation.

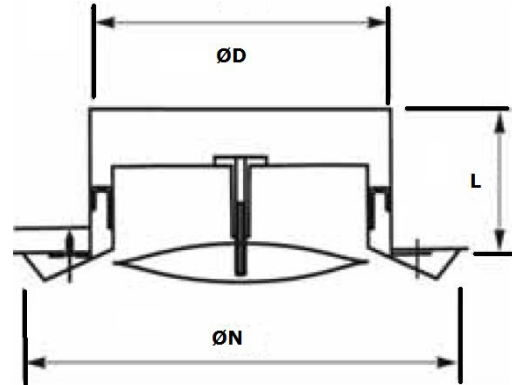

SPECIFICATIONS

SIZE	ØD (mm)	ØN (mm)	L (mm)	Qv (3m/s) [m³/h]
DVI100	100	140	50	80
DVI125	125	170	50	130
DVI150	150	208	63	170
DVI160	160	218	63	180
DVI200	200	298	80	220

Qv	Type	100	125	150	160	200
30	Ps	15				
	L'	0.2				
40	Ps	25	11			
	L'	0.4	0.3			
60	Ps	53	23	3	2	
	L'	0.7	0.4	0.3	0.2	
80	Ps	100	51	10	8	
	L'	1.2	0.7	0.5	0.4	
130	Ps		139	25	22	43
	L'		1.5	1	0.9	1.1
190	Ps			56	48	56
	L'			1.8	1.6	1.6
220	Ps					114
	L'					2

Remarks

Qv = Air Volume in m³/h

L' = Horizontal throw in m at end velocity

LIABILITY:

The information contained in this brochure was current on the publication date. DEC INTERNATIONAL reserves the right to make changes in details at any time without prior notice. In order to avoid misunderstandings, any interested party is advised to contact DEC INTERNATIONAL checking for any changes in materials and/or information after this brochure was published.

PLEASE NOTICE:

The consultant is responsible for the actual installation and mounting of the product. The mentioned values with respect to temperatures are not appropriate to be used to determine the physical properties. These properties are also dependent on humidity and the temperature of the air inside and outside of the H.V.A.C. system.

TRADEMARKS:

DEC International and the DEC logo are trademarks, or registered trademarks of Dutch Environment Corporation BV in the Netherlands and/or other countries.

